

ITEM	QTY.	PART NO.	DESCRIPTION
------	------	----------	-------------

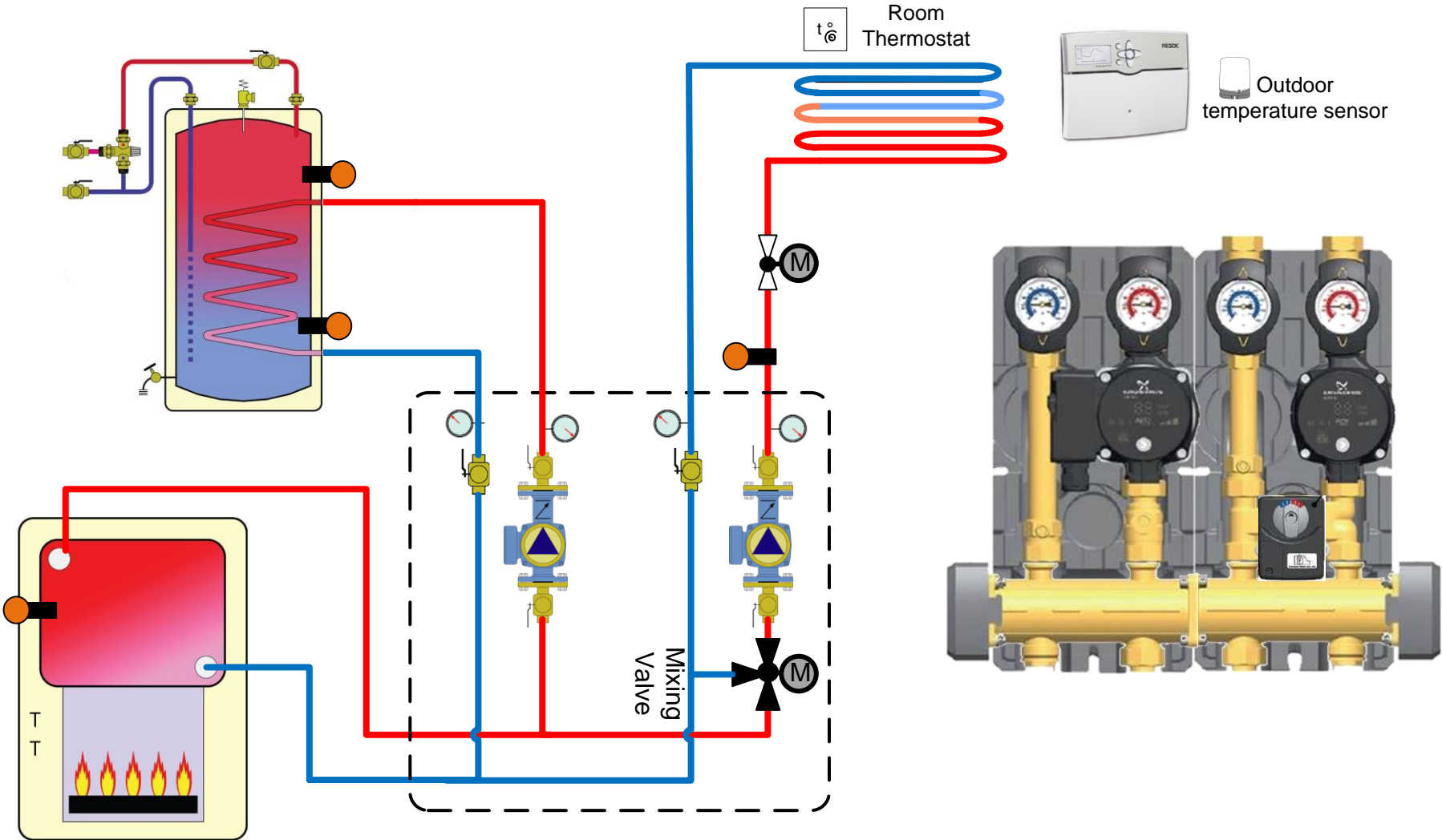

DRAWN	L.Y
ISSUED	10-10-10

SIZE	FSCM NO	DWG NO	REV
		2 Zone/1 DHW, 1 Radiant Zone	
SCALE	NTS	SHEET	1 OF 3